

# U-GAGE® Q45UBB Ultrasonic Sensor

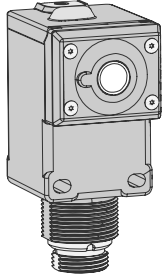

## Datasheet

Piezoelectric proximity mode sensor with push button programming of sensing window limits; bipolar discrete outputs



- Ultrasonic proximity detection from 100 mm to 1400 mm (4 in to 55 in)
- Push-button TEACH-mode programming of sensing window limits
- Digital filtering for exceptional immunity to electrical and acoustic noise
- 12 DC to 24 V DC operation
- Bipolar outputs: one NPN and one PNP
- ON/OFF presence detection or HIGH/LOW level control are switch selectable
- Wide operating temperature range of  $-25^{\circ}\text{C}$  to  $+70^{\circ}\text{C}$  ( $-13^{\circ}\text{F}$  to  $+158^{\circ}\text{F}$ ); some models are available with temperature compensation
- Rugged design for use in demanding sensing environments; rated IP67, NEMA 6P
- Choose models with an integral unterminated 2 m (6.5 ft) or 9 m (30 ft) cable, or with a 7/8 in-16UNF or M12 quick-disconnect connector
- External enable/disable feature for remote gating control

Analog models and models with other ranges are also available



**WARNING:**

- **Do not use this device for personnel protection**
- Using this device for personnel protection could result in serious injury or death.
- This device does not include the self-checking redundant circuitry necessary to allow its use in personnel safety applications. A device failure or malfunction can cause either an energized (on) or de-energized (off) output condition.

## Models

Model	Temperature Compensation	Connection	Response Time
Q45UBB63DA	No	2 m (6.5 ft)	Programmable for 20, 40, 160, or 640 milliseconds
Q45UBB63DAQ		Integral 5-pin 7/8 in-16UNF male quick-disconnect connector	
Q45UBB63DAQ6		Integral 5-pin M12 male quick-disconnect connector	
Q45UBB63DAC	Yes	2 m (6.5 ft)	
Q45UBB63DACQ		Integral 5-pin 7/8 in-16UNF male quick-disconnect connector	
Q45UBB63DACQ6		Integral 5-pin M12 male quick-disconnect connector	

Models with Temperature Compensation—An increase in air temperature shifts both sensing window limits closer to the sensor. Conversely, a decrease in air temperature shifts both limits further away from the sensor. The shift is approximately 3.5% of the limit distance for a  $20^{\circ}\text{C}$  change in temperature. Temperature compensated models maintain the position of both sensing window limits to within 1% of each limit distance over the range of from  $0^{\circ}$  to  $+50^{\circ}\text{C}$ , and to within 2.5% over the full operating range of from  $-25^{\circ}$  to  $+70^{\circ}\text{C}$ .

To order the 9 m (30 ft) cable models, add the suffix “W/30” to the model number of any cabled sensor (e.g., Q45UBB63DA W/30).

Models with a QD connector require an optional mating cable.

## Overview

**Near and Far Sensing Limit Settings.** The Q45U features a single push button for programming the sensing window near and far limits.

**Status Indicators.** Status indicator LEDs are visible through the transparent, o-ring sealed polycarbonate top cover. Indicator function in the Run mode is as follows:

- The green LED is on when power is applied to the sensor and flashes to indicate an overloaded output.
- The red LED flashes when an echo is received; the flash rate is proportional to echo strength.
- The amber LED is on when the outputs are conducting.



Figure 1. Q45U Long-Range Features

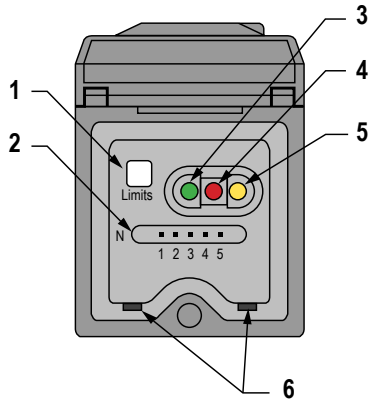

1. Button for programming the sensing window limits
2. 5-Segment target position indicator (N = Near)
3. Green power indicator
4. Red signal indicator
5. Amber output indicator
6. Slots for removing the inner cover

The 5-segment moving dot LED indicator displays the relative position of the target within the programmed sensing window. The #1 LED flashes when the target is closer than the near limit. The #5 LED flashes when the target is beyond the far limit.

### Setting the DIP Switches

Follow these steps to select the output response settings.



**Important:** Disconnect the power before making any internal adjustments.

1. Insert a small flat-blade screwdriver into the slots.
2. Lift up and remove the black inner cover to expose the 4-position DIP switch.
3. Use the DIP switches to program the following functions:

Figure 2. Q45U Programming Switches

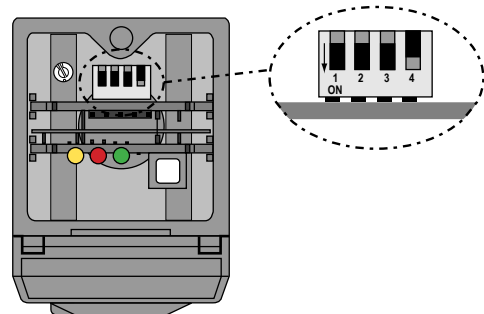

\* Factory default setting

Description	1	2	3	4
ON/OFF Mode: Normally closed output (output energizes when target is absent) HIGH/LOW Mode: Pump out	ON			
ON/OFF Mode: Normally open (output energizes when target sensed) HIGH/LOW Mode: Pump in	OFF *			
Select HIGH/LOW Mode (fill level control)		ON		
Select ON/OFF Mode (the output follows the sensing action)		OFF *		
Response time (20 ms/cycle): 1 cycle (20 ms)			OFF	OFF
Response time (20 ms/cycle): 2 cycles (40 ms)			ON	OFF
Response time (20 ms/cycle): 8 cycles (160 ms)			OFF *	ON *
Response time (20 ms/cycle): 32 cycles (640 ms)			ON	ON



**Important:** A response setting of 2 cycles or higher is recommended for optimum sonic and electrical noise immunity. Always use the slowest acceptable response speed for your application. Single cycle update is only recommended for short range (< 50 cm) applications looking for a stationary target.

Figure 3. High/Low Control (DIP Switch 2 in ON)

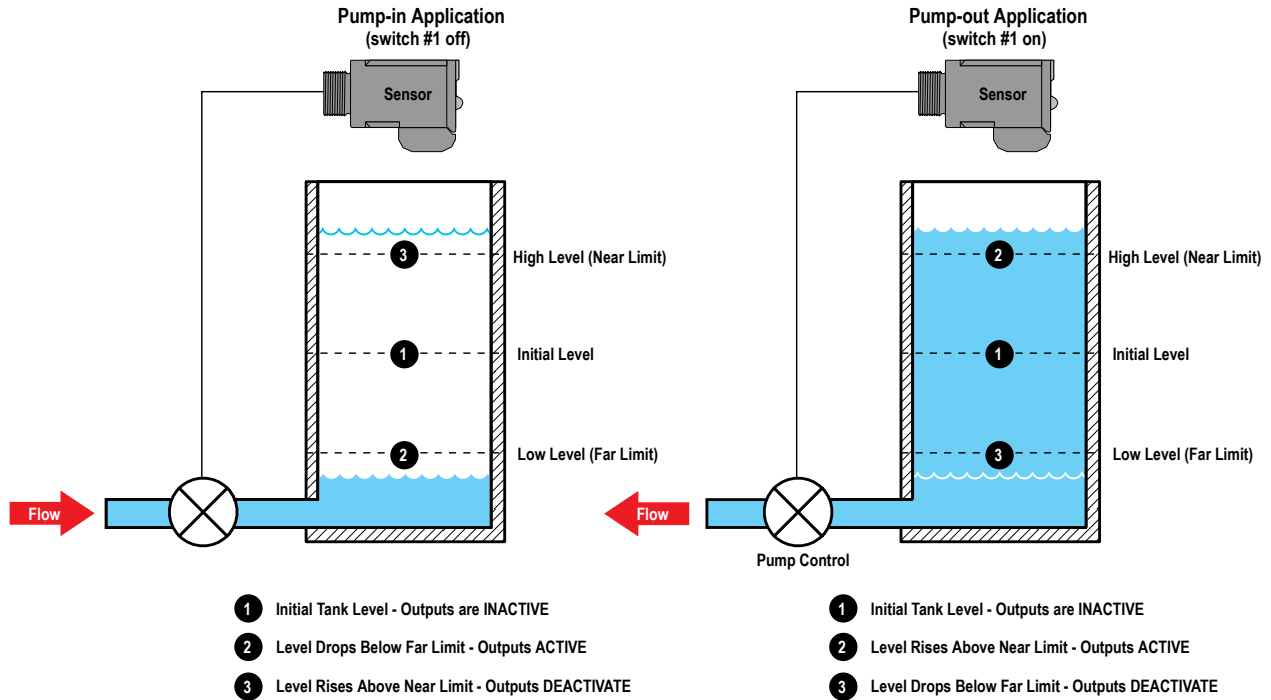

**Note:** If no echo is received by the sensor, the target is assumed to be beyond the far window limit.

The HIGH/LOW mode (DIP switch 2 is ON) provides the switching logic required for fill-level, web tensioning control, and similar applications. In the HIGH/LOW mode, the output energizes when the target reaches the first sensing window limit, and stays energized until the target moves to the second limit. The output then de-energizes at the second limit and does not re-energize until the target moves, again, to the first limit. The figure shows how pumping action might be controlled, directly, by the sensor in a fill-level application.

### Programming the Window Limit

Use the **Limits** button, located under the transparent top cover, to program the near and the far limits.

The near limit may be set as close as 100 mm (4 in) and the far limit may be set as far as 1400 mm (55 in) from the transducer face. The minimum window width is 10 mm (0.4 in). When possible, use the actual target to be sensed when setting the window limits. Programming the window limit begins with the sensor in Run mode.

1. Push and hold the **Limits** button until the green LED turns off (approximately 2 seconds).

Green LED	Amber LED	Red LED
Off	On to indicate the sensor is ready to program the first limit	Flashes to indicate the strength of the echo; Off if no target is present

2. Set the first limit (near or far) by placing the target at the first limit and pressing the **Limits** button for less than 2 seconds.

Green LED	Amber LED	Red LED
Off	Flashes at 2 Hz to indicate the sensor is ready to program the second limit	On for a moment, then resumes flashing to indicate the strength of the echo

3. Set the second limit (far or near) by placing the target at the second limit and pressing the **Limits** button for less than 2 seconds.

Green LED	Amber LED	Red LED
Off, then turns on when the sensor returns to Run mode	On for a moment, then is either on or off to indicate the output state when the sensor returns to Run mode	On for a moment, then resumes flashing to indicate the strength of the echo when the sensor returns to Run mode

Notes regarding window limit programming:

1. Either the near or far limit may be programmed first.
2. There is a 2-minute timeout for programming of the first limit. The sensor returns to Run mode with the previously programmed limits. There is no timeout between the programming of the first and second limit.

3. Cancel the programming sequence at any time by pressing and holding the **Limits** button for  $\geq 2$  seconds. The sensor returns to Run mode with the previously programmed limits.
4. During limit programming, the 5-segment moving dot indicator displays the relative target position between 0 m and 1500 mm. The maximum recommended far limit position is 1400 mm.
5. If the target is positioned between 1400 mm and 1500 mm, the 5th segment of the moving dot indicator flashes to indicate that a valid echo is received, but the target is beyond the recommended 1400 mm maximum far limit.
6. If a limit is rejected during either programming step, the sensor reverts to the first limit programming step. This is indicated by the green LED (OFF), red LED (flashing to indicate signal strength), and the amber LED (ON).
7. If both limits are accepted, the sensor returns to Run mode, which is indicated by the green LED (ON).
8. If the target is held at the same position for programming of both limits, the sensor establishes a 10 mm wide sensing window, centered on the target position.

## Wiring Diagrams

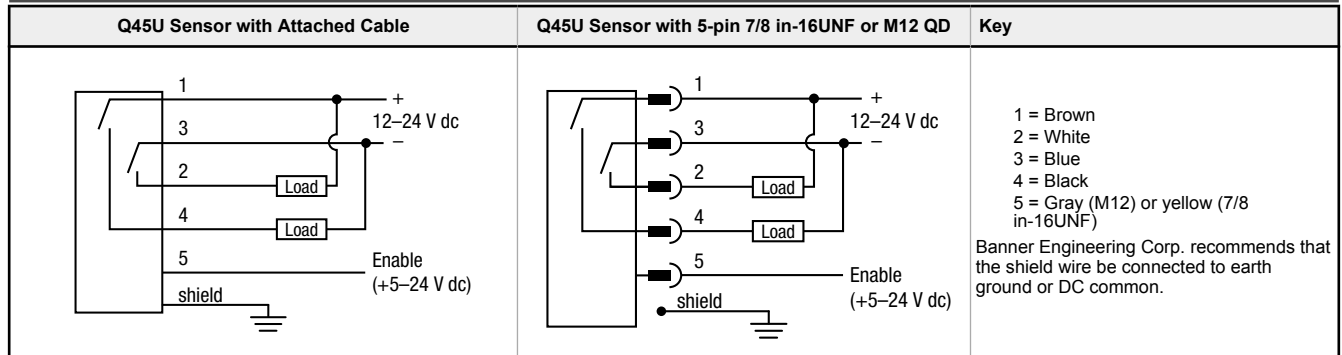

## Specifications

### Supply Voltage and Current

12 DC to 24 V DC (10% maximum ripple) at 100 mA, exclusive of load

### Proximity Mode Range

Near limit: 100 mm (4 in) minimum  
 Far limit: 1.4 m (55 in)

### Supply Protection Circuitry

Protected against reverse polarity and transient voltages

### Output Rating

150 mA maximum (each)  
 Off-state leakage current: < 25 microamp at 24 V DC  
 On-state saturation voltage: < 1.5 V at 10 mA; < 2.0 V at 150 mA

### Performance Specifications

Repeatability:  $\pm 0.1\%$  of measured distance ( $\pm 0.25$  mm min)  
 Minimum Window Width: 10 mm (0.4 in)  
 Hysteresis: 5 mm (0.2 in)

### Output Protection Circuitry

Protected against false pulse on power-up and continuous overload or short-circuit of outputs

### Construction

Molded PBT thermoplastic polyester housing, o-ring sealed transparent acrylic top cover, and stainless steel hardware.  
 Q45U sensors are designed to withstand 1200 psi washdown.  
 The base of cabled models has a 1/2"-14 NPS internal conduit thread

### Connections

2 m (6.5 ft) or 9 m (30 ft) attached cable, integral 5-pin 7/8 in-16UNF male quick-disconnect connector, or integral 5-pin M12 male quick-disconnect connector

### Hysteresis

ON/OFF mode: 5 mm  
 HIGH/LOW mode: 0 mm

### Certifications



**Banner Engineering Europe**  
 Park Lane,  
 Culliganlaan 2F bus 3,  
 1831 Diegem, BELGIUM

**Turck Banner LTD**  
 Blenheim House,  
 Blenheim Court,  
 Wickford, Essex SS11  
 8YT, Great Britain

### Output Configuration

Bipolar: one PNP and NPN open-collector transistor  
 Use the 4-position DIP switch to select the following:

- Switch 1: Output normally open/normally closed (pump in/pump out)
- Switch 2: High/Low level control mode or on/off presence sensing mode
- Switch 3 & 4: Response speed selection (digital filter)

### Environmental Rating

Leakproof design is rated IP67; NEMA 6P

### Indicators

Three status LEDs:

- Green ON = power to sensor is ON
- Green flashing = output is overloaded
- Amber ON = outputs are conducting (in Run mode); or programming status (in Setup mode)
- Red flashing = indicates relative strength of received echo

5-segment moving dot LED indicates the position of the target within the sensing window

### Operating Conditions

Temperature:  $-25^{\circ}\text{C}$  to  $+70^{\circ}\text{C}$  ( $-13^{\circ}\text{F}$  to  $+158^{\circ}\text{F}$ )  
 Maximum relative humidity: 100%

### Vibration and Mechanical Shock

All models meet MIL-STD-202F, Method 201A (Vibration: 10 Hz to 60 Hz maximum, 0.06 inch (1.52 mm) double amplitude, 10G maximum acceleration) requirements. Also meets IEC 60947-5-2 (Shock: 30G 11 ms duration, half sine wave) requirements. Method 213B conditions H & I (Shock: 75G with unit operating; 100G for non-operation).

### Application Notes

Minimum target size: 10 mm  $\times$  10 mm aluminum plate at 500 mm (20 in) and 35 mm  $\times$  35 mm aluminum plate at 1.4 m (55 in)  
 Enable/Disable: Connect the yellow wire to +5 to 24 V DC to enable the sensor and 0 to +2 V DC to disable the sensor. When the sensor is disabled, the last output state is held until the sensor is re-enabled. Hold the wire to the appropriate voltage for at least 40 ms to enable or disable the sensor.

## Performance Curves

**Effective Beam with Plate Target (Typical)**

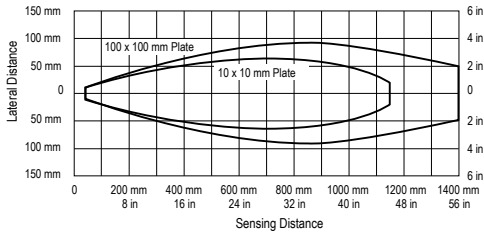

**Effective Beam with Rod Target (Typical)**

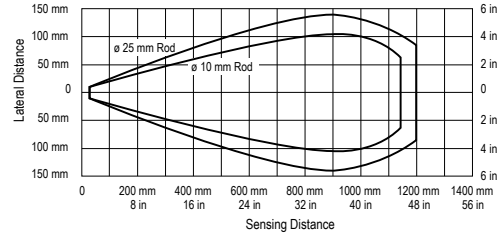

## Dimensions

**Cabled Models**

**5-pin 7/8 in-16UNF QD Models**

**5-pin M12 QD Models**

Transparent Cover (Gasketed)

View: Sensing Status  
Output Load Status  
Power

Open to Access:  
Push Button for  
Programming of Sensing  
Window Limits

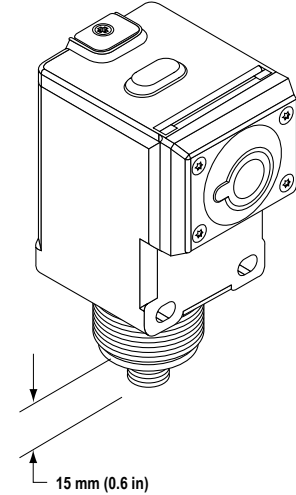
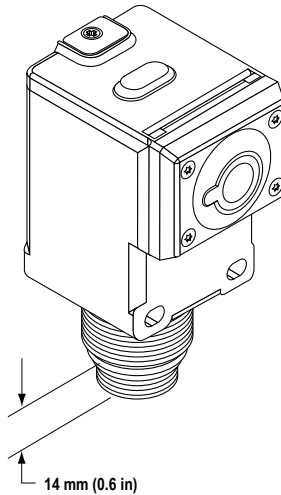
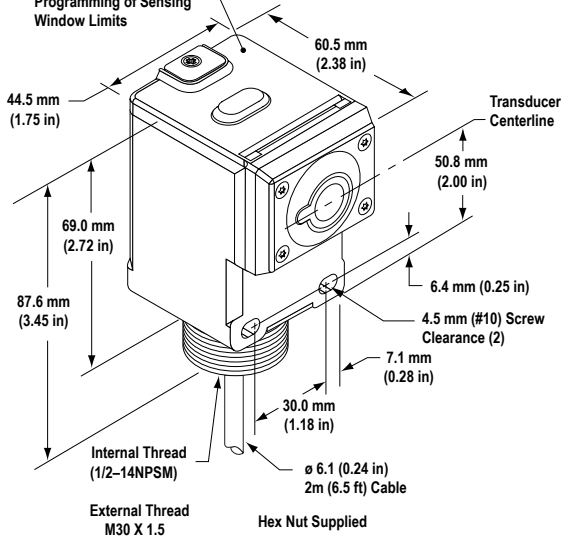

## Accessories

### Cordsets

5-Pin 7/8-in Cordsets with Shield—Single Ended				
Model	Length	Style	Dimensions	Pinout (Female)
MBCC2-506	2 m (6.56 ft)	Straight		<p>1 = Brown 2 = White 3 = Blue 4 = Black 5 = Yellow</p>
MBCC2-512	4 m (13.1 ft)			
MBCC2-530	9 m (29.5 ft)			